



Defender™ 5000

Low Profile Scales



Smart Functionality, Durability, OHAUS Quality and Value

The OHAUS Defender™ 5000 Series is a feature-rich line of bench scales, combining an ABS plastic T51P indicator with painted steel bases and mounting brackets. Ideal for shipping and receiving, production, packaging and general commercial and industrial weighing applications, the Defender 5000 offers a multifunctional indicator with multiple weighing units and software modes to meet the requirements of industrial and lab applications. With rugged construction, comprehensive yet intuitive software and multiple connectivity options, the Defender 5000 can meet the needs of demanding industrial operations.

Standard Features Include:

- Painted steel bases with ABS indicator
- 10,000-12,500d default resolution for square bases, 5,000-7,500d default resolution for rectangular bases
- 1:5,000 NTEP Certified / Measurement Canada Approved for square bases, up to 1:3,000 for rectangular bases
- Quick display of results using large LCD with high-contrast white backlight
- Temporary display of 10x readability in weighing mode using quick key press
- Easy to operate with 4-key membrane keypad with raised tactile keys
- Weighs in one or more units: kg, g, lb, oz, lb:oz (decimal), metric tonnes and user-definable custom unit
- Multiple weighing modes including Counting, Percent Weighing, Dynamic/Animal Weighing, Checkweighing, and Display Hold.
- Internal power supply with universal line cord or 6 "C" batteries (80 hour battery life) – optional NiMH internal rechargeable power pack available
- Includes RS232 interface with GMP/GLP data output including date and time
- Base and indicator connected using quick connect plug
- Optional interfaces include DC relay control kit, AC relay control kit, 2nd RS232 and RS485/422

Defender™ 5000 Low Profile Scales

The Defender 5000 Offers Multiple Features and Easy Configuration:

To meet different operational needs, the Defender 5000 includes a suite of configurable software:

- Counting mode for packaging and inventory control, enabling counting into a container or out of a container for bulk operations. Supports a maximum counting resolution to 1:300,000 (minimum APW equal to 0.1d), selectable auto-optimization of average piece weight (APW). APW data can be displayed at any time using a quick key press.
- Percent Weighing mode for formulation and mixing applications, with display of reference weight with quick key press.
- Dynamic/Animal Weighing with selectable weigh times from 0-60 seconds.
- Checkweighing function for packaging and weight checking, with display of results using LCD display and red/yellow/green LEDs. Audible beeper can be configured to prompt when weight is within range, under, over, or under or over range. Target weight values can be displayed at any time using a quick key press.
- Display Hold mode for weighing large packages holds last stable weight on display until cleared
- The Defender 5000 weighs in one or more user-selectable units: kg, g, lb, oz, lb:oz (decimal), metric tonnes and user-definable custom unit
- Supports GMP/GLP data output with date, time user ID, project ID and scale ID. The Defender 5000 features selectable print options for data and print format
- To limit operator access to functions, the Defender 5000 offers both software lockouts for menu items as well as individual key functions.

Features

T51P Indicator: ABS plastic housing with internal rib reinforcements, reversible rear cover, backlit LCD weight display, checkweighing indication (green, yellow, red), membrane keypad with raised tactile keys, built-in bi-directional RS232 with manual/continuous/interval printing, external tare input, hardware configuration lockout switch, internal switching power supply with line cord and battery power using 6 “C” cell batteries.

Other Features

Zero point calibration, calibration test, span or linear calibration, selectable auto-zero tracking range, selectable stability range, selectable averaging level, selectable LCD backlight, selectable auto shutoff, retain zero weight data after power-off, Geo gravity adjustment, selectable key beep, key function lock, menu lock, selectable power-on and calibration unit, battery status display, display of gross/net weight, indication of stability, center of zero, over- and underweight, overload and underload conditions. Configuration menus for PRINT1, PRINT2, COM1, COM2, and I/O.

Compliance

- **Legal for Trade:** NTEP (CC No. 08-039 for indicator; 01-048A1 for square base; 99-203A3 for rectangular base) Measurement Canada (Approval No. AM-5687 for Indicator; AM-5719 for square bases; AM-5675 for rectangular bases)
- **Safety and EMC:** UL_{us} 2005/95/EC low voltage directive: EN60950-1:2001, FCC Part 15 Class A 2004/108/EC Compliant to Directive 202/96/EC on waste electrical and electronic equipment (WEEE)
- **Quality:** OHAUS quality management system registered to ISO 9001:2008

Outline Dimensions

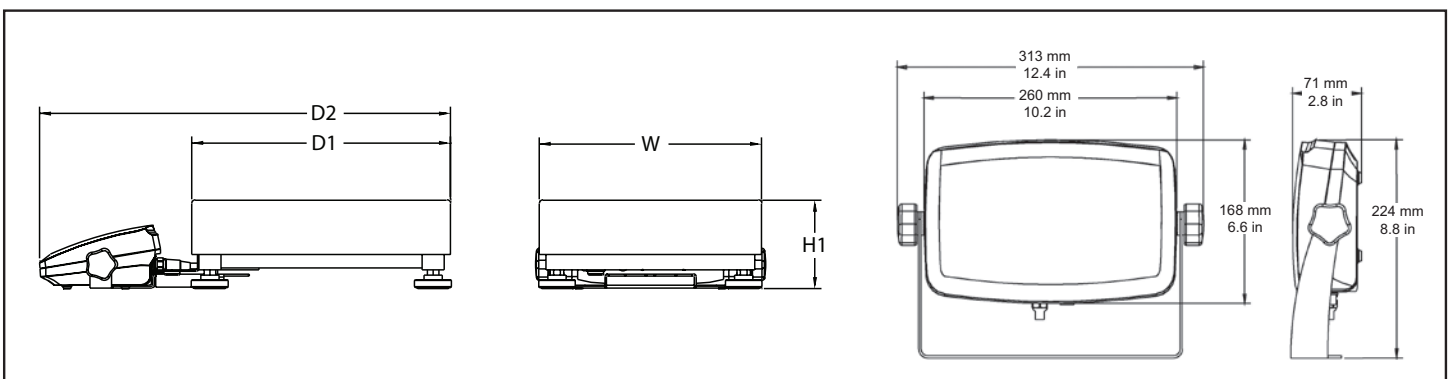

Standard Features:

Choice of Two Base Designs
Available in higher-precision square bases or lower-precision rectangular bases.

Durable Base Frame Construction
Stainless steel pans and painted steel form-and-weld frames (R, L bases) provide maximum durability, rigidity and structural integrity. Load-unload cycle tested to ensure long-term performance.

Internal Slot for Capacity Label
Protects label from the effects of moisture and external environments

3-Color LED Checkweigh Indication
with configurable beeper alert

High-Visibility LCD Display
with bright white LED back-light and fast display stable weight within 2 seconds

Fully Adjustable Feet
Four rugged, adjustable feet help prevent slippage on wet or uneven surfaces

Universal Switching Power Supply
100-240 VAC with AC line cord; no need for an external AC adapter!

Simple Plug-In Battery Installation
Use six C- alkaline batteries or the optional NiMH battery

Stay Connected
Built in RS232 bi-directional interface and, external input, optional RS485/422, optional second RS232 and optional AC or DC relay

One-Key, Multiple Mode Selection
Counting, Dynamic Weighing, Display Hold, Percent Weighing and Checkweighing

Reinforced Indicator Housing
Internal structural ribs provide strength and minimize flexing.





Options and Accessories

Interface Options	OHAUS Number
AC Relay Kit.....	80500720
DC Relay Kit.....	80500727
RS485/422 Interface Kit.....	80500731
Second RS232 Interface Kit.....	80500733
Foot Switch.....	71173378
Power Options	
Rechargeable Battery Kit, T51P/T51XW.....	80500729

Other Accessories	OHAUS Number
Compact Dot Matrix Impact Printer.....	80252042
Compact Thermal Printer.....	80251992
OHAUS Collect Software.....	80500746
TAL Software WinWedge.....	SW12W
Paper for Printer, 80252042 (1 roll).....	80251932
Ribbon for Printer, 80252042.....	80251933
RS232 Cable & Adapter, 80252042 Printer to T51P.....	80252571
RS232 Cable, PC 9-pin to T51P.....	80500525
RS232 Cable, PC 25-pin to T51P.....	80500524

Defender™ 5000 Low Profile Scales

Low-Profile Square Scales

Model	D51P10QR5	D51P25QR5	D51P50QL5	D51P100QL5	D51P250QX5
Capacity x Default Readability	25 lb x 0.002 lb 400 oz x 0.05 oz 25 lb : 0.05 oz 10 kg x 0.001 kg 10,000 g x 1 g	50 lb x 0.005 lb 800 oz x 0.1 oz 50 lb x 0.1 oz 25 kg x 0.002 kg 25,000 g x 2 g	100 lb x 0.01 lb 1,600 oz x 0.2 oz 160 lb : 0.2 oz 50 kg x 0.005 kg 50,000 g x 5 g	250 lb x 0.02 lb 4,000 oz x .5 oz 250 lb : .5 oz 100 kg x 0.01 kg 100,000 g x 10 g	500 lb x 0.05 lb 8,000 oz x 1 oz 500 lb : 1 oz 250 kg x 0.02 kg 250,000 g x 20 g
Maximum Displayed Resolution	1:10000	1:12500	1:10000	1:10000	1:12500
Capacity x Certified/Approved Readability	25 lb x 0.005 lb 10 kg x 0.002 kg	50 lb x 0.01 lb 25 kg x 0.005 kg	100 lb x 0.02 lb 50 kg x 0.01 kg	250 lb x 0.05 lb 100 kg x 0.02 kg	500 lb x 0.10 lb 250 kg x 0.05 kg
Maximum Certified Resolution	1:5,000	1:5,000	1:5,000	1:5,000	1:5,000
Safe Overload Capacity	150% of maximum capacity				
Scale Dimensions (W x H1 x D1 x D2)	12 x 3.7 x 12 x 20.8 in 305 x 95 x 305 x 530 mm		18 x 4.5 x 18 x 26.8 in 457 x 115 x 457 x 680 mm		24 x 5.4 x 24 x 32.8 in 610 x 137 x 610 x 833 mm
Shipping Dimensions (L x W x H)	19.3 x 16.1 x 17.3 in 490 x 410 x 440 mm		31.2 x 23.6 x 9.5 in 810 x 600 x 240 mm		39.4 x 29.9 x 9.8 in 1000 x 760 x 250 mm
Net Weight	30.6 lb / 13.9 kg		63.7 lb / 28.9 kg		80.9 lb / 36.7 kg
Shipping Weight	35.9 lb / 16.3 kg		68.5 lb / 31.1 kg		95.0 lb / 43.1 kg

Low-Profile Rectangular Scales

Model	D51P15HR5	D51P30HR5	D51P60HR5	D51P60HL5	D51P100HL5	D51P150HX5	D51P300HX5
Capacity x Default Readability	30 lb x 0.005 lb 480 oz x 0.1 oz 30 lb : 0.1 oz 15 kg x 0.002 kg 15,000 g x 2 g	60 lb x 0.01 lb 960 oz x 0.2 oz 60 lb x 0.2 oz 30 kg x 0.005 kg 30,000 g x 5 g	150 lb x 0.02 lb 2,400 oz x 0.5 oz 160 lb : 0.5 oz 60 kg x 0.01 kg 60,000 g x 10 g	250 lb x 0.05 lb 4,000 oz x 1oz 250 lb : 1oz 100 kg x 0.02 kg 100,000 g x 20 g	300 lb x 0.05 lb 4,800 oz x 1 oz 300 lb : 1 oz 150 kg x 0.02 kg 150,000 g x 20 g	600 lb x 0.1 lb 9,600 oz x 2 oz 600 lb : 2 oz 300 kg x 0.05 kg 300,000 g x 50 g	
Maximum Displayed Resolution	1:7500	1:6000	1:7500	1:5000	1:7500	1:6000	
Capacity x Certified/Approved Readability	30 lb x 0.01 lb 15 kg x 0.005 kg	60 lb x 0.02 lb 30 kg x 0.01 kg	150 lb x 0.05 lb 60 kg x 0.02 kg	250 lb x 0.1 lb 100 kg x 0.05 kg	300 lb x 0.1 lb 150 kg x 0.05 kg	600 lb x 0.2 lb 300 kg x 0.1 kg	
Maximum Certified Resolution	1:3,000	1:3,000	1:3,000	1:2,500	1:3,000	1:3,000	
Safe Overload Capacity	150% of maximum capacity						
Scale Dimensions (W x H1 x D1 x D2)	12 x 3.7 x 14 x 22.8 in 305 x 95 x 355 x 580 mm			15.7 x 4.1 x 19.7 x 28.5 in 400 x 105 x 500 x 725 mm		16.5 x 4.9 x 21.7 x 30.5 in 420 x 125 x 550 x 775 mm	
Shipping Dimensions (L x W x H)	19.3 x 16.1 x 17.3 in 490 x 410 x 440 mm			29.1 x 27.2 x 9.1 in 740 x 690 x 230 mm		29.5 x 30 x 9.1 in 750 x 710 x 230 mm	
Net Weight	23.6 lb / 10.7 kg			46.3 lb / 21.0 kg		58.2 lb / 26.4 kg	
Shipping Weight	35.9 lb / 12.7 kg			53.6 lb / 24.3 kg		64.8 lb / 29.4 kg	

General Specifications

Indicator Model	T51P
Construction	ABS plastic indicator, stainless steel removable weighing platform, aluminum loadcell, painted steel mounting bracket and base construction
Weighing Units	lb, oz, lb:oz, kg, g, metric tonnes, custom unit
Modes	Static Weighing, Dynamic Weighing, Counting, Checkweighing, Percent Weighing, Display Hold
Display	1 in / 25mm high 6-digit, 7-segment bright white backlit LCD
Keyboard	4-button membrane switch
Stabilization Time	Within 2 seconds
Auto-zero Tracking	Off, 0.5, 1 or 3 d
Zeroing Range	2% or 100% of capacity
Calibration	Span: 1kg or 1lb to 100% of capacity / 3-point linearity (0 - 50% - 100% fixed)
Power	100-240 VAC / 50-60Hz internal universal power supply, 6 'C' cell batteries (not supplied) with 80 hour life
Interface	RS232 and external input
Operating Temperature Range	14°F to 104°F / -10°C to 40°C

Ohaus Corporation

* 19A Chapin Road
P.O. Box 2033
Pine Brook, NJ 07058 USA

Tel: 800.672.7722
973.377.9000
Fax: 973.944.7177

www.ohaus.com

With offices throughout Europe,
Asia, and Latin America

* ISO 9001

Registered Quality Management System

